

## Moxon Rectangles for 6 Meters



L. B. Cebik, W4RNL (SK)

I have had numerous requests over the last few years for the dimensions and construction plans for Moxon rectangles designed for the 6-meter band. The Moxon rectangle is a quite broad-band antenna, but it is not quite broad enough to cover the entire band. As well, the lower end of the band is the major arena for horizontal polarization using CW or SSB. The upper portion of the band sees most of the FM activity, with vertical polarization being standard.

Hence, for full band coverage--or for selected use of one or the other mode of activity--we really need 2 Moxons. The first will be a horizontally oriented beam designed for 50.5 MHz with coverage of the first MHz of the band. The second will be a vertically oriented version designed for 53 MHz, with coverage from 52 to 54 MHz. After looking at the characteristics of these two versions of the same basic design, we shall make a few construction suggestions. Finally, we shall show how to combine them into a single array--but with separate feedlines.

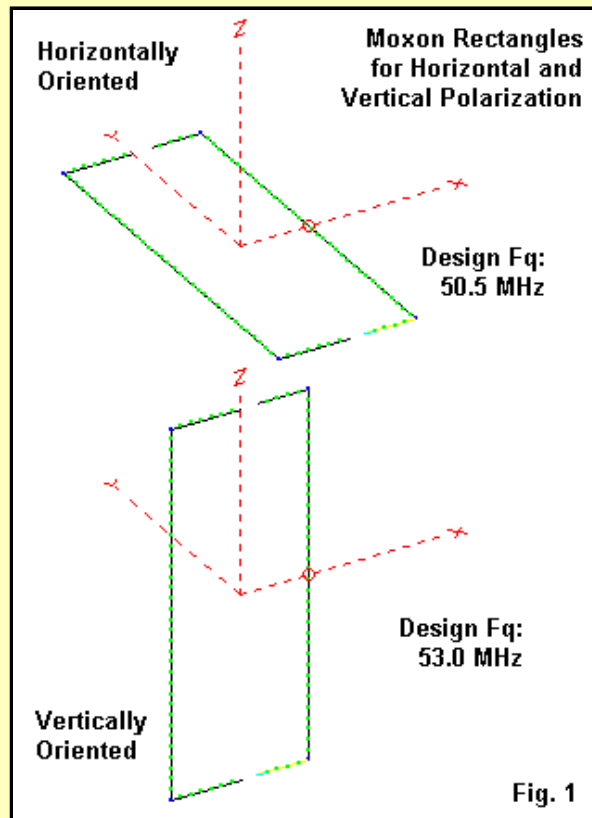

**Fig. 1** shows the general outlines of the two types of Moxons. The Moxon is a driver-reflector type of parasitic array. Unlike standard Yagi designs that employ only the coupling between parallel lengths of element conductor, the Moxon folds back its elements to provide a second form of coupling. The coupling of the driver and reflector tails that face each other provides a second form of coupling, and the combination of the two gives us an array that we can design for very good front-to-back performance, about as much forward gain as a 2-element Yagi, and a 50-Ohm feedpoint impedance for direct connection of a standard coaxial cable feedline.

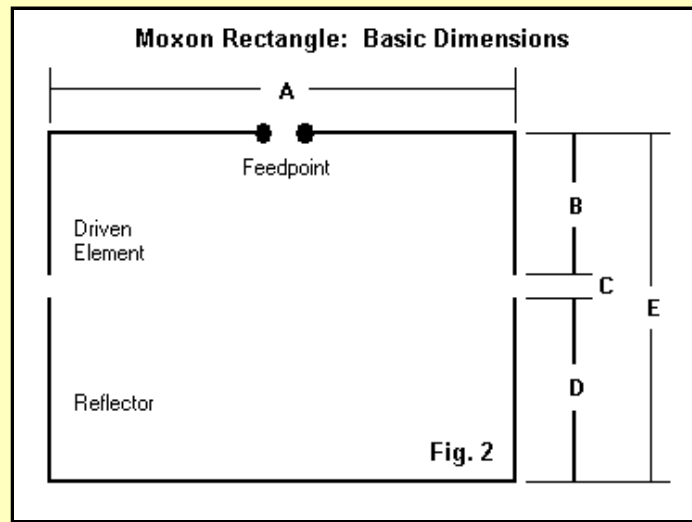

Since we need a way to refer to the parts of a Moxon when giving dimensions, **Fig. 2** supplies what has become a set of default designations. Dimension A is the total side-to-side dimension of the array. B is the driver tail or fold-back portion, and D is the reflector fold-forward portion or tail. C is the most critical dimension, the gap, and tends to vary as a direct function of the element diameter. E is simply the sum of B, C, and D, and gives us the total front-to-back dimension of the array.

All 6-meter Moxons will be about 7' wide or about 3.5' each side of the center line. The front-to-back dimension will be about 2.5', plus or minus a little. Hence, the Moxon makes a very compact array, suitable for enhancing repeater communications or for SSB operation in local nets.

In fact, the precise dimensions for a 50-Ohm Moxon for any frequency and element diameter have been developed into several computer programs, ranging from a GW Basic utility in the HAMCALC suite to a NEC-Win Plus model to a stand-alone Windows program developed by AC6LA and available for free download from his site (<http://www.qsl.net/ac6la>). Since all of them are based on the same modeling and regression analysis that I performed some time back, all will give the same dimensions for the same design frequency and element diameter.

Let's start our foray into 6-meter Moxons with the low-end horizontal version.

### A Horizontal Moxon Rectangle for 50.5 MHz.

The materials that folks have access to will vary from region to region. Therefore, let's make a chart of dimensions. All of the dimensions will presume that we are using some form of aluminum tubing, ranging from 1.0" down to 0.25" in diameter. As we shall see in the construction section, aluminum tubing is an optimal choice for a 6-meter Moxon.

In the following table, all dimensions refer to **Fig. 2** and are in inches.

.....

**Dimensions for a 50.5-MHz Moxon Rectangle**

El. Dia.	A	B	C	D	E
1.0	83.61	10.40	4.58	16.22	31.20
0.875	83.68	10.53	4.46	16.21	31.20
0.75	83.76	10.69	4.32	16.19	31.20
0.625	83.86	10.86	4.16	16.18	31.20
0.5	83.97	11.07	3.97	16.15	31.19
0.375	84.12	11.32	3.74	16.12	31.19
0.25	84.31	11.65	3.44	16.08	31.18

.....

Note that the dimensions change only a small amount from one tube diameter to the next. Moreover, the front-to-back dimension (E) changes almost not at all. However, the differences are important to centering the performance curve of the Moxon on the design frequency, which then has consequences for

performance at the band edges. So using the dimensions that apply to the element diameter that you will use does have significance.

Let's set the antenna 25' above ground, which is just over 1.34 wavelengths up. The forward gain will be about 11.4 dBi at 50.5 MHz, with a 180-degree front-to-back ratio of about 30 dB and a 78-degree beamwidth between -3-dB points. The feedpoint impedance of 50 Ohms, plus or minus 1 to 2 Ohms reactance.

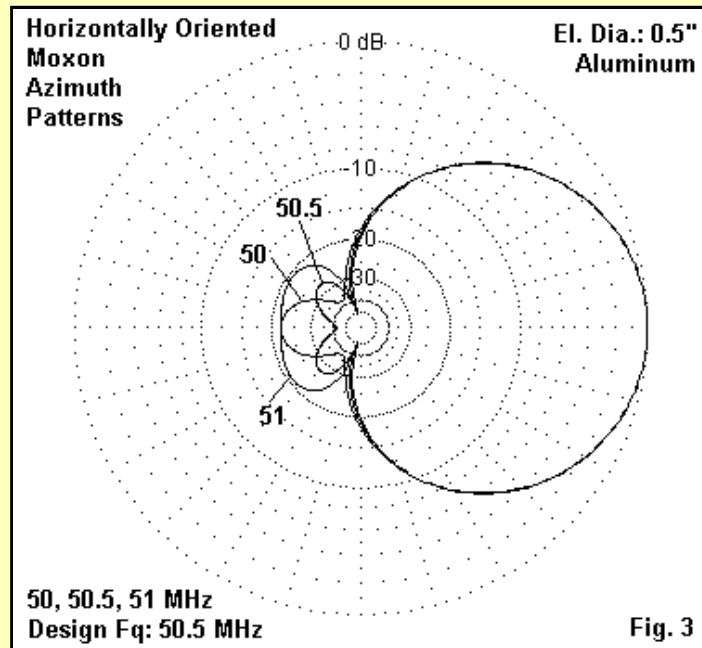

**Fig. 3** overlays the design frequency and the passband edge azimuth patterns of the Moxon rectangle when oriented horizontally. As you can see from the patterns, taken for a version using a 0.5" diameter element set, as we move lower in frequency, the gain increases very slightly (too slightly to ever be measured in operation), and the rearward radiation begins to increase. Above the design frequency, the gain decreases by an equally slight amount, and, again, the rearward radiation pattern shows growth.

The performance of the antenna is virtually unchanged at the design frequency for any tubing size. However, the band-edge performance does change (in this case, using a 1-MHz passband). The fatter the tubing, the slower the rate of forward gain change. More significantly, the fatter the tubing, the slower the growth of rearward radiation lobes both above and below the design frequency. However, those changes are not so great as to override considerations such as the most convenient tubing size for constructing a Moxon rectangle.

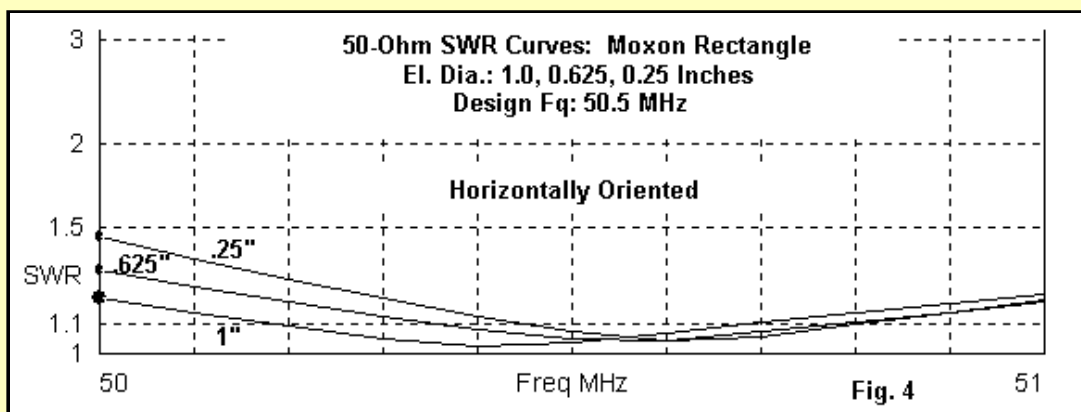

Tubing size also makes a difference in the 50-Ohm SWR for the final antenna, as measured at the antenna terminals, as shown in **Fig. 4**. For a 1-MHz passband, almost any size tubing will do, and the SWR at the shack end of the coax is likely to be too low to get a definite frequency for the lowest value.

#### A Vertical Moxon Rectangle for 53.0 MHz.

The design principles do not change at all when we flip the Moxon rectangle for upper 6-meter service. However, the dimensions will change, since we are now using a design frequency of 53.0 MHz in order to cover the 52-54-MHz range. The following table provides dimensions, again in inches and again using **Fig. 2** as a reference.

.....  
 Dimensions for a 53.0-MHz Moxon Rectangle

El. Dia.	A	B	C	D	E
1.0	79.64	9.86	4.41	15.46	29.73
0.875	79.71	9.99	4.29	15.45	29.73
0.75	79.79	10.14	4.16	15.44	29.73
0.625	79.88	10.31	4.00	15.42	29.73
0.5	79.99	10.50	3.82	15.40	29.72
0.375	80.13	10.75	3.60	15.37	29.72
0.25	80.31	11.07	3.31	15.33	29.71

.....

The last decimal place in column E, the overall front-to-back dimension, may be a digit or two off the sum of B, C, and D due to rounding of the individual values. However, I doubt that any builder will be constructing the elements to a hundredth of an inch tolerances. In fact, in the construction section, we shall be slightly altering the dimensions to take account of the fact that we shall bend the tubing at the corners.

Once more, let's place a 0.5" diameter version of the antenna at a height of 25' above ground. At the design frequency, we shall obtain a 50-Ohm feedpoint impedance accompanied by a front-to-back ratio well above 30 dB. (Vertical orientation affects the front-to-back ratio less than horizontal orientation for an antenna within about 2 wavelengths of ground.) However, unlike the horizontal version of the array, the peak gain is only about 7.6 dBi. Let's see why.

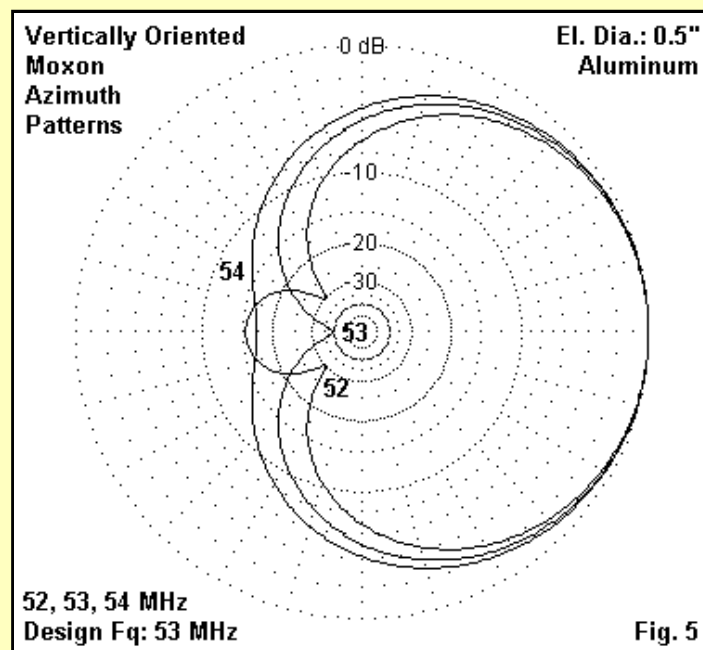

**Fig. 5** overlays the azimuth patterns of the antenna at the design frequency and at 52 and 54 MHz. In all cases, we see a very wide beamwidth, over 142 degrees between -3-dB points. That increased beamwidth--about twice the value for the horizontal version--spreads the radiated power over a much wider area and thus reduces the peak gain. This is inherent in any parasitic array with all of the elements in a single plane. Nevertheless, both the horizontal and the vertical versions of the array have almost 4 dB gain over their counterpart dipoles at the same height.

As the patterns show, the increased bandwidth that we require of a vertical Moxon increases the rearward radiation at the band edges. Once more, the fatter the elements, the less growth to the rearward radiation for any change in frequency relative to the design frequency.

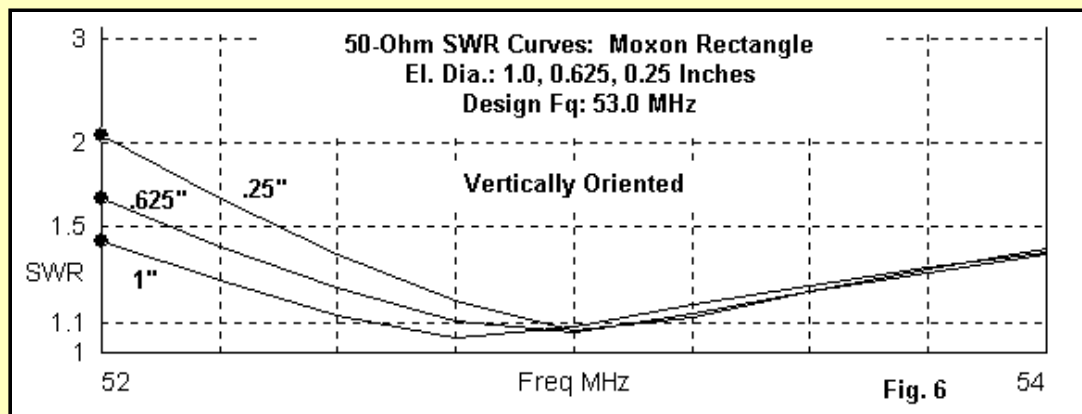

In **Fig. 6**, we have the 50-Ohm SWR curves for the array at selected element diameters. The SWR increases more rapidly below the design frequency than above it. The antenna feedpoint impedance for the thinnest tubing actually is above 2:1, although at the shack end of the coax, where we usually measure SWR, it may seem lower than that value. Hence, one might well think in terms of at least an intermediate tubing size for the vertical Moxon.

The SWR climbs more slowly above the design frequency, suggesting that we might choose a lower design frequency and extend the coverage from 51 to 54 MHz. This tactic is possible, but at a cost. The forward gain and the front-to-back ratio degrade continuously as we move above the design frequency. Hence, with a design frequency of, say, 52 MHz, the array performance would not be very good at 54 MHz.

### Building a Moxon Rectangle for 6 Meters

There is an unfortunate tendency among newer antenna builders to see a design they like and then to grab almost any materials close at hand and slap together a version that almost works. Many a good antenna design has gotten a bad name in some regions because builders did not exercise the same care in construction as the original builder. To obtain performance that agrees with the design notes above, acquire the right materials and then build the antenna with all the care possible.

A good tubing size for a 6-meter Moxon--whether horizontal or vertical--is 0.5". This size is useful, since we can use #8 or #10 hardware for fastenings. Of course, the hardware will all be stainless steel, both for rust prevention and to avoid bi-metallic contact problems.

For a 6-meter Moxon rectangle, we shall need 4 6' lengths of 1/2" diameter tubing. This size tubing can be shipped from suppliers like Texas Towers by UPS. (Yes, we shall have some scrap left over for use as garden stakes.) Use 6061-T6 or 6063-T832. Hardware depot tubing has an unknown vintage, so good quality antenna tubing is highly desirable. Do not use aluminum electrical conduit or copper tubing. The conduit is too heavy, and so is the copper in any form rigid enough not to gradually fold over on its own accord.

We shall also require a short (under 6") length of 3/8" aluminum tubing and a similar length of 3/8" diameter fiberglass or similar rod. We shall be constructing the elements in halves, so we need to join and align them. The short length of 3/8" aluminum tubing will join the two halves of the reflector, making them electrically one. The fiberglass or equivalent rod will align the driver halves, but allow a gap for connecting the feedline. Finally, we shall require some 3/8" outer-diameter fairly rigid tubing, something light but straight. These tubes will fit inside the ends of the driver and reflector tails to hold the spacing constant under all conditions.

For hardware, we shall require some #8 nuts and bolts, along with some locking washers. We can use sheet metal screws to fasten the tail junction tubes in place. However, all hardware must be stainless steel, including the washers. Since some of this falls outside what home warehouse hardware bins contain, consider locating a hardware supplier or use an on-line ordering source like McMaster-Carr. From such sources, you can also obtain a small sheet of 1/4" thick UV-protected polycarbonate (trade-name Lexan) to use as boom-to-element plates. Polycarbonate cuts nicely with woodworking saws and drills cleanly with standard bits.

The needs for a single Moxon rectangle are small, so you may wish to combine orders with others interested in the antenna in order to make up the minimum order requirements for a given supplier. Since we have vowed to be careful, we need not rush to get parts, but can go slowly and get everything we need.

For a boom, you can use either metal or Schedule 40 PVC (if the PVC in your area is adequately UV protected--this varies around the U.S.). In the southeastern US, white PVC gives me about 10 years of service before becoming brittle.

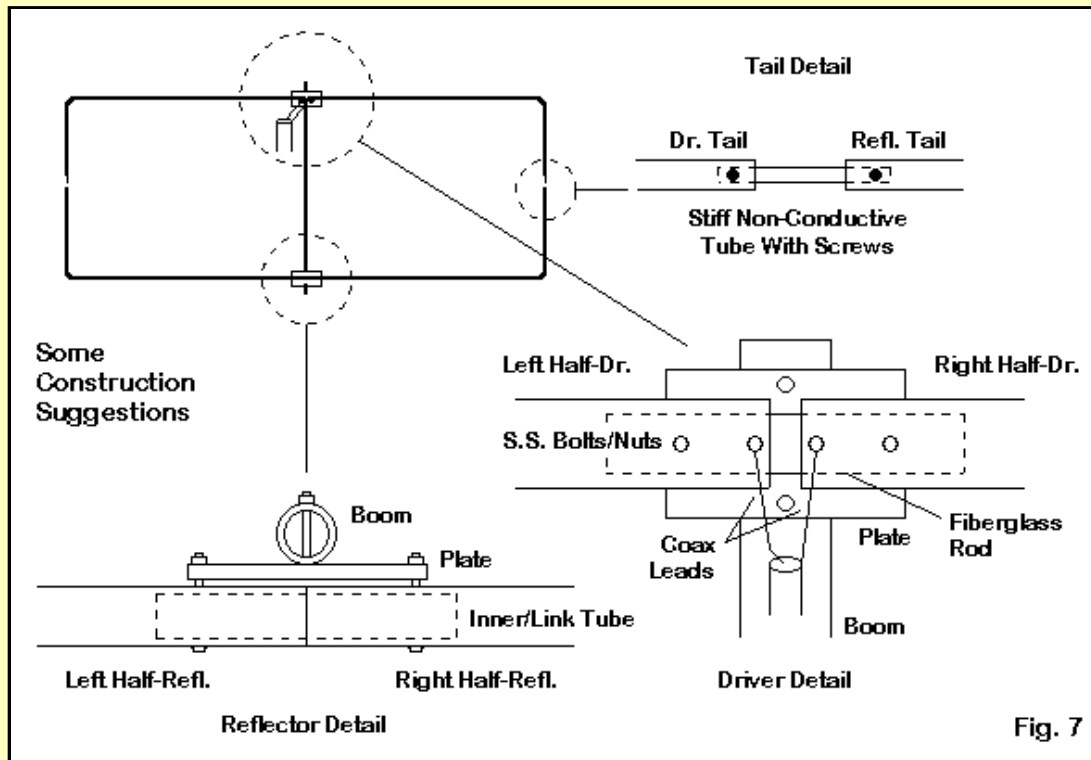

**Fig. 7** shows some of the suggested construction methods that I use. you may have better ones, in which case, use them. There are 4 keys areas of construction concern.

1. *The reflector junction:* A 3/8" section of tubing a little longer than the boom-to-element plate joins the two halves. If we use polycarbonate plates about 4" long and 3" wide, we have plenty of room for the elements and the nuts/bolts for boom fastening. A 1" nominal PVC pipe is actually about an inch and a quarter in diameter and is very rigid for a boom that is less than 3' long. For the plate-to-boom bolts, #10 hardware is very secure, using only 2 bolts per plate. However, use a compression lock washer against the plate or obtain self-locking nuts (with a nylon insert).

Since a #10 bolt requires a larger hole, you may wish to fasten the elements to the plate with #8 hardware, again with compression lock washers against the plate. (Toothed lock-washers may gradually loosen by gouging the polycarbonate.) For all drilling of the boom and the elements, make up a jig from scrap wood to pin the material in place while you drill. If you can gain access to a drill press--even a small device designed to hold an electric hand drill--by all means use it. Align all holes before drilling instead of widening holes later to bring parts into alignment.

2. *The driver gap:* By using a 3/8" fiberglass rod to align the driver halves, we can fasten the driver and the rod to the plate using #8 hardware. Note that there are two sets of hardware at the driver: an outer set to pins the element to the plate and an inner set to which we shall connect the feedline. If you prefer, you can set the connection hardware at right angles to the element-to-plate hardware to keep the coax more in line with the boom.

The sketch shows direct connections between the element and the coax, with no connector. I have found that from 6 meters on upward, connectors and their associated leads contribute reactance to the feedpoint impedance. A direct connection and a short length of coax taped to the boom for strain relief simplifies feedpoint construction. Once everything is complete, seal the connections, especially since solder terminals may not be available in stainless steel. Plasti-Dip or similar materials provide a weather-secure coating.

*A note on the gap:* The gap at the feedpoint is part of the overall element length (or dimension A), NOT an addition to it. Whether you start with a 1/4" gap or a much wider one, let the driver side-to-side dimension remain constant. In effect, the coax leads make up the seemingly missing tubing. The driver gap is not critical from 1/4" to over 3/4", but closer is always better in this type of antenna.

3. *The tail separation:* Because we must keep the tail ends at a specified distance and aligned, we need a short piece of non-conductive tubing to lock their relative positions. Almost anything will do here, if it is 3/8" in outside diameter and relatively rigid. We shall need only about 4-4.5 inches exposed, so even flexible nylon tubing will work, although rigid plumbing CPVC is superior. You may use sheet metal screws to fasten the tube inside the tail pieces--after careful measurement, of course.

4. *The element bends:* Bending aluminum tubing requires care to prevent crimping that will eventually result in a metal crack and break. The radius of the corner bends will depend on the tubing size used. A plumber's tubing bender is applicable only up to about 1/4" diameter tubing. Larger tubing requires larger bend radii, and that means a home-made jig.

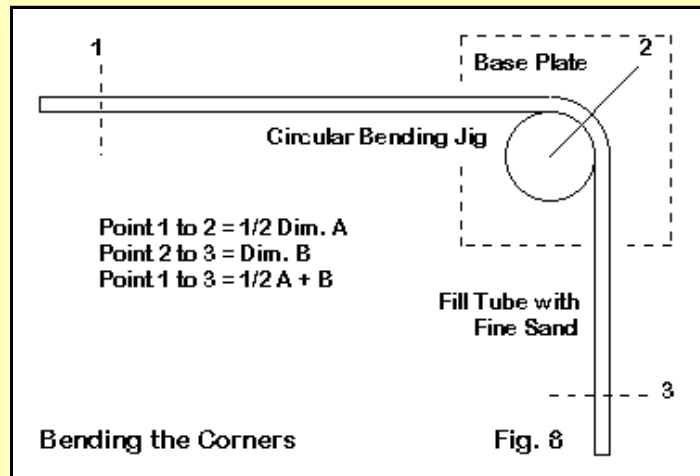

**Fig. 8** shows a simple jig: a circle mounted on a base plate. The circle can be cut from plywood or be a pulley wheel. For larger radius bends, I have used such materials as a worn-out power mower wheel.

Mark a point on the 6' length of tubing that marks the center of the bent corner and leaves excess on both the tail and the parallel sections. Try to keep this mark at the center of the bend. As well, mark the tubing to indicate the parallel length (1/2 of dimension A) and the tail (B or D, as applicable). Fill the tube with the finest sand available and tape the end shut. If you prefer, warm the tube until it can just barely be handled with gloves. Pin one end of the tube (a nail in the base board will do) and slowly bend the tubing. The fatter the tubing, the more important it is to bend a few degrees and pause. Continue the bend until it is at least a 90-degree bend. A little more will not hurt, since a slight unbending of the tube does no harm.

Bend the tubing before you drill any mounting holes to make sure that all such holes are at right angles to the mounting plates. In fact, let's delay any drilling and do some work on the floor.

From the dimensions that apply to your tubing size, draw out the Moxon on the floor (or on paper taped to the floor). Be sure to mark the center or boom line as well as the points where the tails end. Next, lay the untrimmed bent pieces on the drawing. Because the corners are "clipped" by the bending, the pieces will just exceed the lines on the floor.

**NOTE:** For the adjustment of positions, be sure that the gap is constant and does not change!

With a constant gap distance as specified for the tubing size and measured against the marks made on the tubing, adjust the tube position to equalize the amount by which the tubes fall outside the original lines. At the same time, align the tubes. Now trim the tubes. Remember to trim a bit (1/8" or so per tube) off the driver to leave a gap for the coax connection. Smooth all cuts. Aluminum oxide sandpaper is best so that you do not leave residues of other metals on the aluminum. Clean the outer and inner edges of the tubes, since you will be inserting rods or tubes inside the main elements.

Now return to the assembly process and complete the Moxon rectangle. If you have used sufficient care, it should be right on target on the first try. However, you can always trim a bit more from the reflector and driver tubes at their centers--and a little expansion that leaves a little inner reflector tube showing and widens the driver gap a small amount should do no harm.

I assume that you have a boom-to-mast plate and stainless steel U-bolt hardware. As well, I assume that the coax from the feedpoint has a connector and a double-female in-line connector. If those assumptions are correct, you are ready to put the Moxon rectangle into service.

## Crossed Moxons

Suppose that you have both SSB and FM operations on 6 meters and that you decide that the Moxon has characteristics that are suitable for each job. Then you may wish to think about **Fig. 9**.

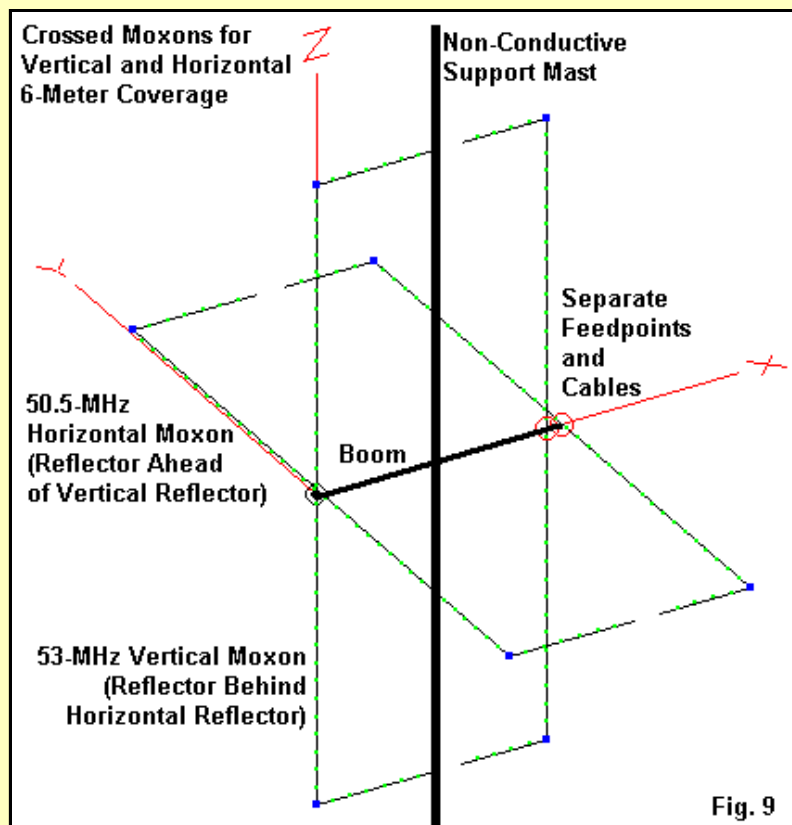

The outline sketches crossed Moxon rectangles. Since the low-end horizontal version is a bit larger than the vertical high-end version, let's place the horizontal reflector slightly ahead of the vertical reflector. Actually, it will make no difference if the two reflector join at the center. However, we shall need physically separate feedpoints--and separate feedlines as well. However, the assembly will fit on a single boom.

Crossing Moxons and operating them separately makes no difference at all to the performance of either one.

One precaution applies to either a single vertical Moxon or to crossed Moxons: we shall need a non-conductive boom if we attach the mast at the center of the boom. (6-meter arrays are heavy enough where I do not recommend extending the boom rearward for attachment to a mast without a further extension and counterweight.) Schedule 40 PVC has two sizes that nest reasonably well for stiffening the material for mast use: 1" inside 1-1/4" nominal (closer to 1.25" and 1.5" actual outside diameters). You will need about 3.5' to go from the boom to the edge of the vertical Moxon and perhaps another 2' above any metal structure (like a tower), plus a few more feet to reach a rotator. (An old TV rotator is more than sufficient to handle even the crossed Moxons). However, do not use more PVC mast than you need to do the job.

### A Wire Moxon for 6 Meters?

As a final note, we should address the question of making a wire Moxon. A #12 or #14 copper wire Moxon is feasible for the horizontal version only. However, the thin wire will narrow the passband severely. If you operate within a very narrow spread of frequencies at the low end of the band, then you may consult one of the design aids and set up a wire version. It will perform well--as well as the tube version. As well, it may be easier to make sharp corners and trim to length.

However, a wire version of the vertical Moxon is likely to prove unsatisfactory for repeater hopping. It will work well for monitoring a single repeater--or a couple that are within a half-MHz of each other (allowing for the frequency split). However, for general coverage of the FM region of 6 meters, a version with fatter elements is strongly advised.

We can illustrate the opportunities and the limitations of a wire Moxon for 6 meters with a simple example. Let's design a wire Moxon for horizontal use around the design frequency of 50.5 MHz. The dimensions will be as follows:

.....

**Dimensions for a 50.5-MHz Moxon Rectangle**

El. Dia.	A	B	C	D	E
<b>AWG #14 (0.0641")</b>	<b>84.86</b>	<b>12.53</b>	<b>2.61</b>	<b>15.95</b>	<b>31.09</b>
0.25	84.31	11.65	3.44	16.08	31.18

.....

I left the figures of the quarter-inch version for comparison. As shown in **Fig. 10**, the wire Moxon has a steeper gain curve and a sharper front-to-back curve than the tube version of the same antenna. However, for local and net operations, these figures may be very adequate.

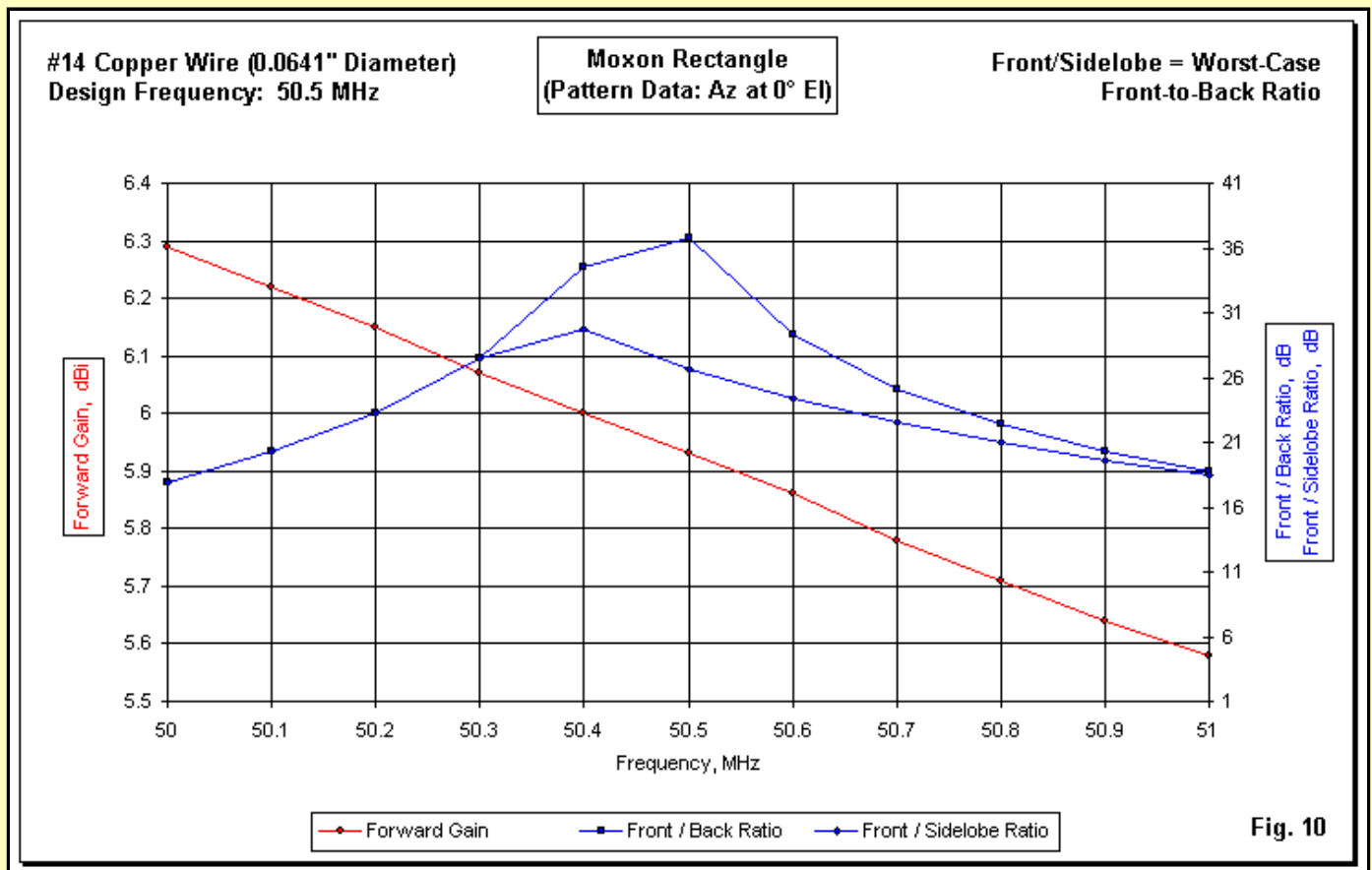

The SWR curve, while steeper than the ones for the tube versions of the antenna, guarantees coverage of the first MHz of the band. See **Fig. 11**. You may note in the two graphs that the front-to-back ratio peaks just below the design frequency, as does the 50-Ohm SWR curve.

#14 Copper Wire (0.0641" Diameter)  
Design Frequency: 50.5 MHz

Moxon Rectangle  
(Pattern Data: Az at 0° El)

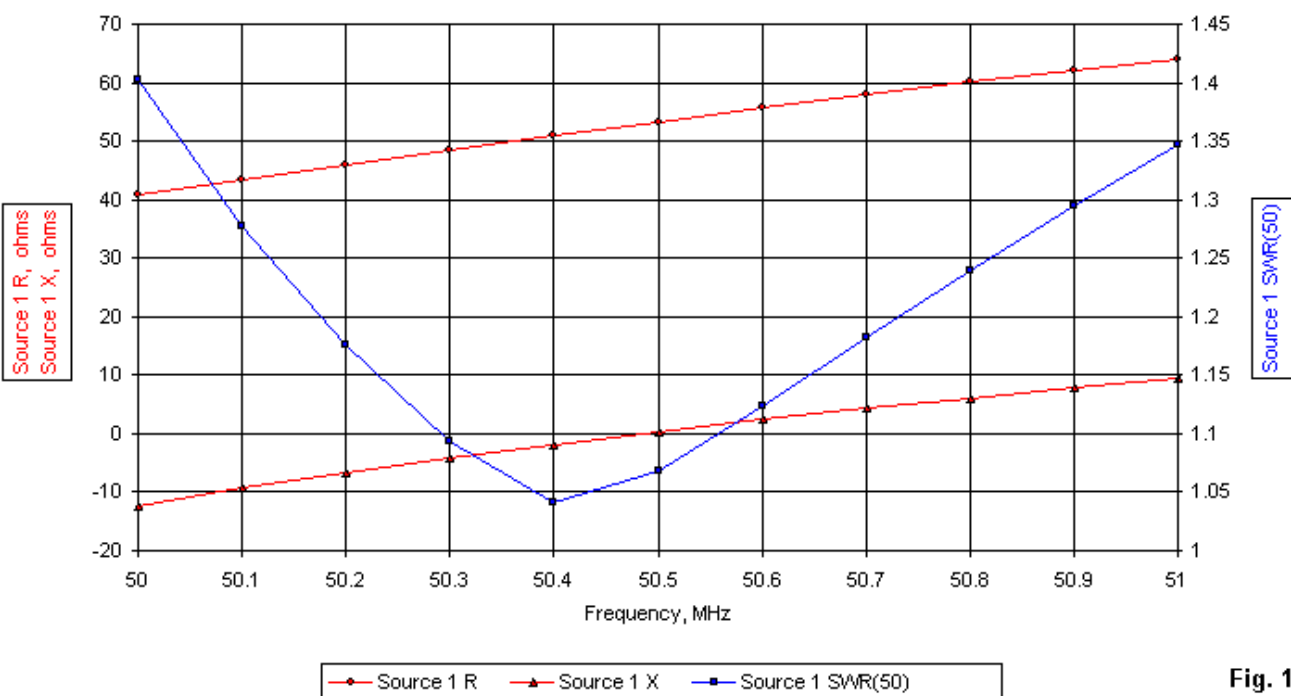

Fig. 11

You can make the frame from 1/2" or 3/4" CPVC. By passing the frame through carefully aligned holes in a central Schedule 40 PVC mast, you can cement the structure together. Each cross arm will need to be just over 7.5' long (3.75' each side of the mast). As well, you will have to plan your angles for the holes carefully to get the correct shape between corners. However, if you are only a little off, you can stress the arms with Nylon line (1/8" to 3/16") to perfect the shape of the ultimate support structure. If you adjust the holes in the mast, then add through bolts to finalize the positions of the support arms. The details of a suggested construction for the frame, line, and wires appears in Fig. 12.

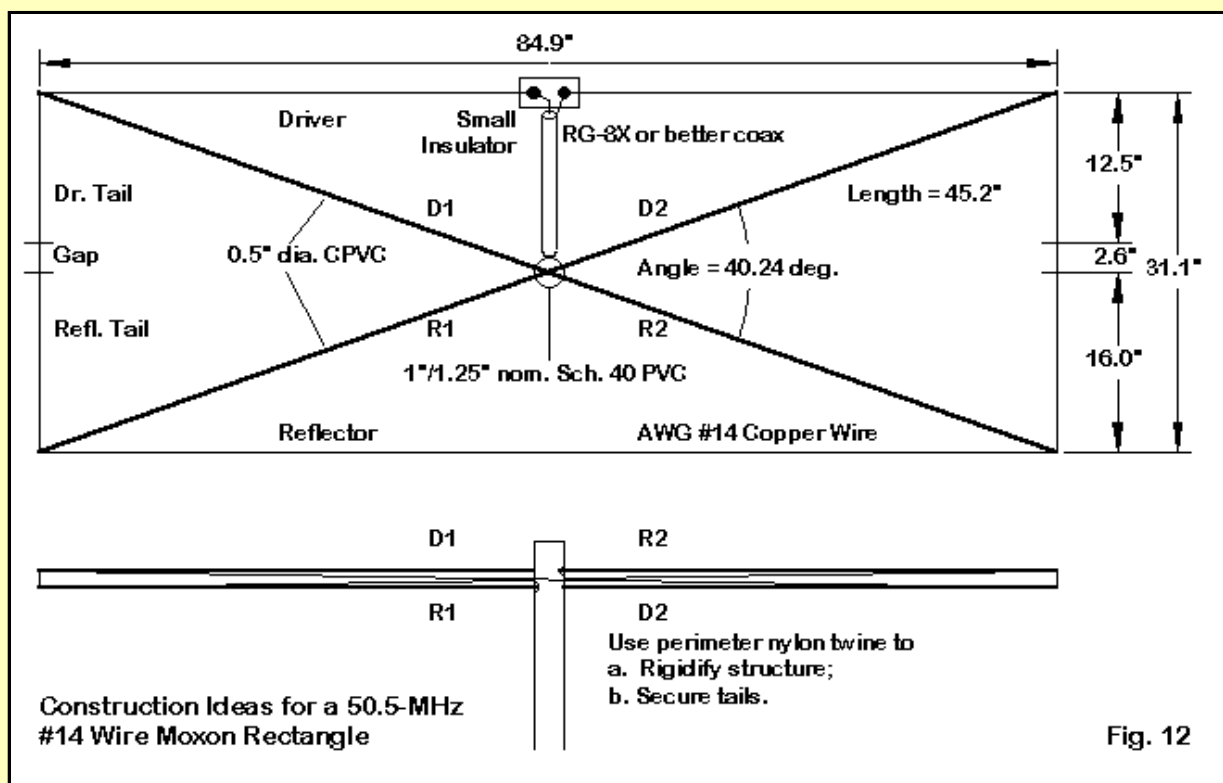

Fig. 12

Even if you get the angles between supports correct, you may still run a length of nylon or similar line from the corners along the line of the tails. Then, tape the tails to this line, and the ends (raw cut and not looped) will stay in alignment and maintain their spacing. (I tend to prefer to use a full perimeter line to pre-stress the frame so that it maintains its shape under all conditions.) The resulting wire Moxon very likely will be considerably cheaper than any of the tube versions, since we can make it from PVC and household wire, along with a little hardware at the feedpoint.

Whether the Moxon is the right antenna--and which version is the one to build--depends on your own analysis of operating needs. Do not build one unless it will do the job that you need. But if you do build one, build it carefully, and it will work correctly without further field adjustment.



[Return to Moxon Index](#)



[Go to Amateur Radio Page](#)